

COMPARTMENT DIMENSIONS			
COMP.#	DOOR OPENING	INTERIOR	DIVIDE HEIGHT
L1	30"W x 60"H	32"W x 72"H	27"
L2	68"W x 28"H	75"W x 40"H	14"
L3	48"W x 28"H	48"W x 28"H	N/A
L4	48"W x 28"H	48"W x 28"H	25"
R1	30"W x 33"H	32"W x 37"H	27"
R2	48"W x 33"H	48"W x 37"H	14"
R3	48"W x 28"H	48"W x 28"H	N/A
R4	48"W x 28"H	48"W x 28"H	25"

GROUND LADDERS & PIKE POLES			
ITEM	DESCRIPTION	MODEL #	QTY
A	24'-2-SEC EXTENSION	PEL-24	1
B	14' ROOF	PEL-14	1
C	10' FOLDING ATTIC	FL-10	1
D	PIKE POLE		3

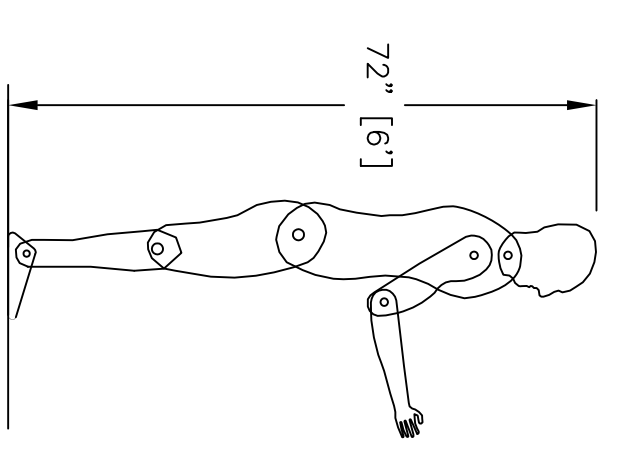
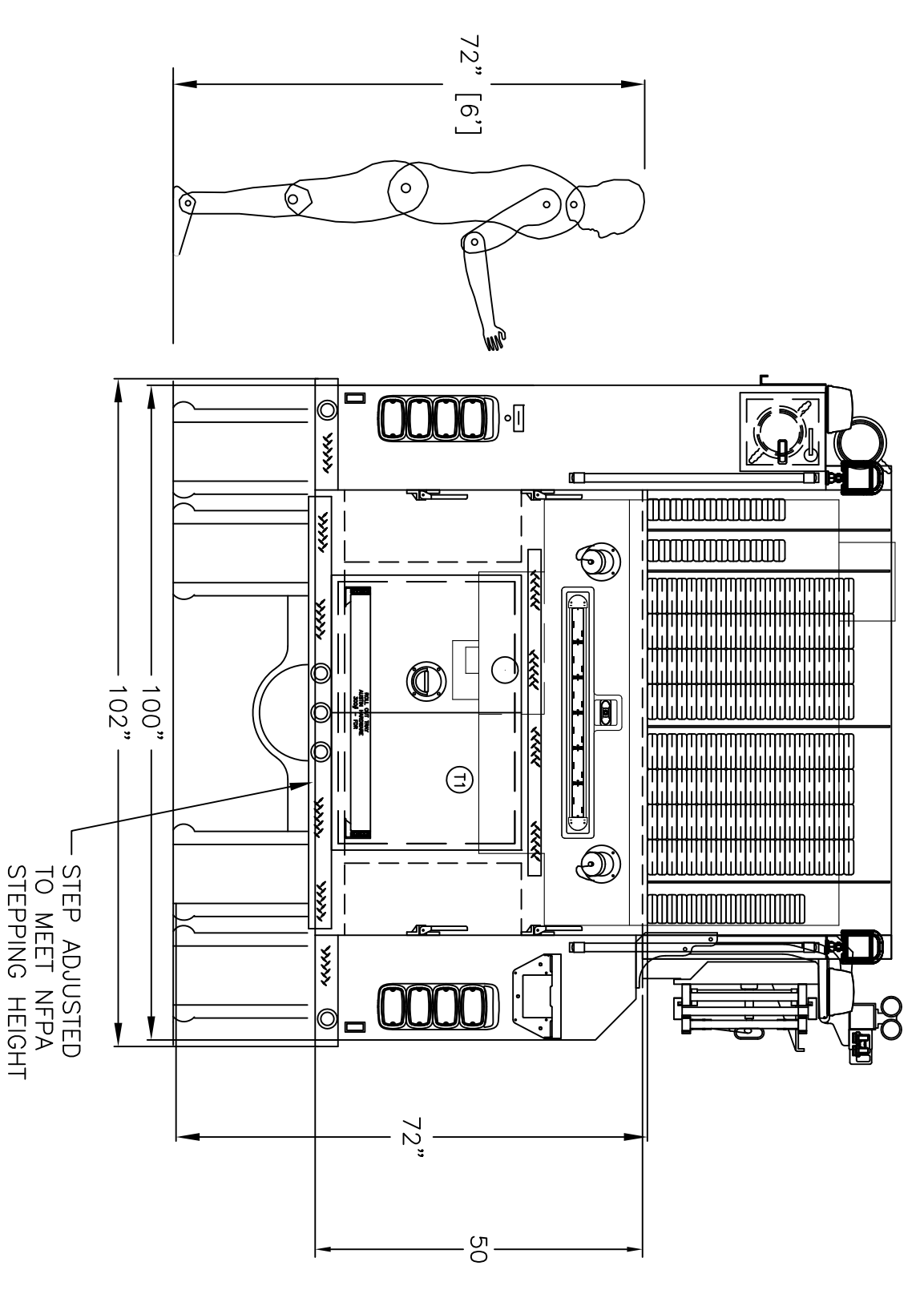
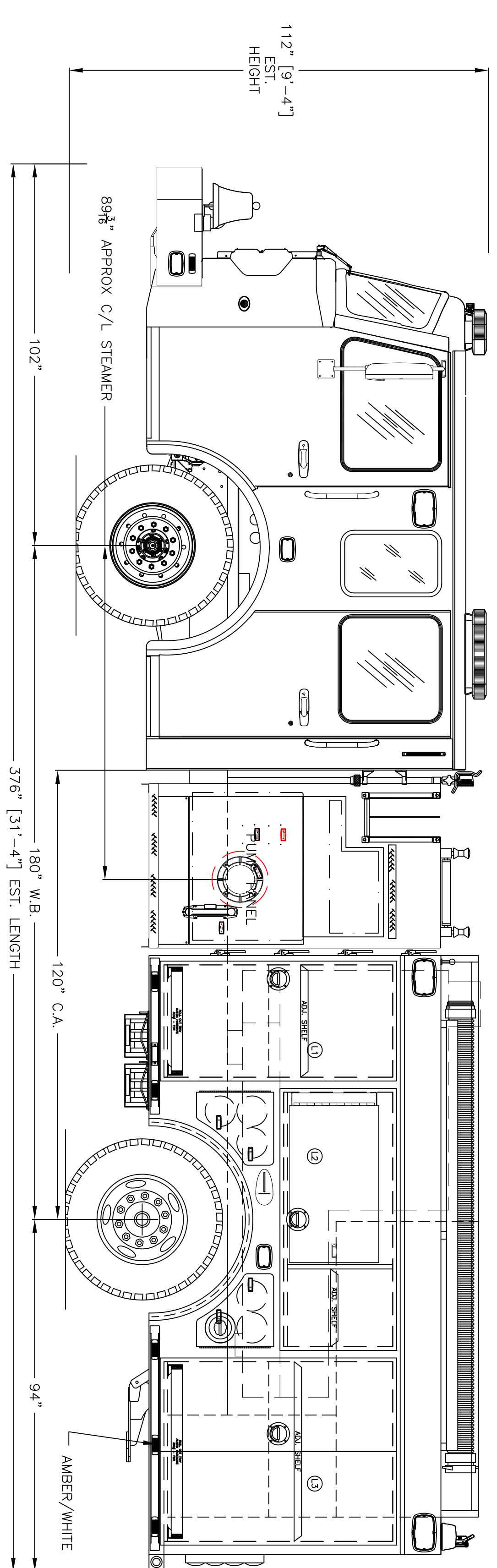

**NOTE:**  
 THIS DRAWING IS THE PROPERTY OF Smeal Fire Apparatus Co. and is to be used only in reference to the work proposed or contracted by Smeal Fire Apparatus Co. Any reproduction in part or in whole without the written permission of Smeal Fire Apparatus Co. is strictly prohibited.  
 DIMENSIONS SHOWN ARE APPROXIMATE AND ARE SUBJECT TO CHANGE AS MAY BE FOUND NECESSARY DURING CONSTRUCTION. THIS DRAWING MUST BE PLOTTED TO THE PAPER SIZE LISTED IN THE TITLE BLOCK FOR THE LISTED SCALE TO BE VALID.  
 THIS DRAWING IS FOR REFERENCE PURPOSES ONLY. SOME ITEMS MAY OR MAY NOT APPEAR ON THE DRAWING THAT MAY OR MAY NOT BE INCLUDED IN THE SPECIFICATIONS. **THE SPECIFICATIONS SHALL BE THE FINAL AUTHORITY TO DETERMINE WHAT IS SUPPLIED ON THE APPARATUS.**

REV.	NO.	DATE	REVISION HISTORY
01	SOS	8/2/17	ORIGINAL LAYOUT FOR ORDER ENTRY
02	CDM	5/19/18	PRIMARY RELEASE

**SHOP ORDER**

**CHASSIS:**  
 SPARTAN METRO SHAR EMFD FLAT ROOF  
 ENGINE: 1900 HP  
 WATER TANK: 1000 U.S. GAL.  
 FLOW: 1500 GPM  
 BODY MATERIAL: 1/8" ALUMINUM  
 HOSE BED: 115 CUBIC FEET  
 COMPARTMENTS: N/A  
 11/2 CUBIC FEET

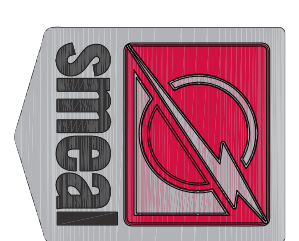

**SMEAL FIRE APPARATUS CO.**  
 610 W 4TH ST  
 SNYDER, NE  
 PHONE: (402) 568-2224  
 WWW.SMEAL.COM

**TOWN OF BRISTOL**  
 BRISTOL, RI  
 SIDE MOUNT PUMPER  
 NEFEA  
 DRAWN BY: STUMPE  
 DATE: 8/2/17  
 SCALE: 1/2" = 1'  
 SHEET: 24 X 36"  
 DRAWING NO: S4828  
 REV: 01