

ALL COMPARTMENT DIMENSIONS GIVEN ARE ROUGH OPENING

**NOTES**

Not all items being specified are shown on this print. Refer to customer specifications for a review of all details.

DO NOT SCALE PRINTS  
All dimensions are in decimal inches.

**PROJECT**

NEW ENGLAND FIRE:  
COMMAND VEHICLE

**CHASSIS**

FORD F350

**COMPARTMENTS**

Label	Size	W X H X D	ROUGH OPENING
D1	78.0 X 35.5 X 26.5		78.0 X 35.5
D2	11.0 X 23.5 X 9.0		11.0 X 23.5
R1	43.5 X 35.0 X 33.5		43.5 X 35.0
P1	78.0 X 35.5 X 8.5		78.0 X 35.5
P2	11.0 X 23.5 X 9.0		11.0 X 23.5
P3	11.0 X 13.5 X 9.0		11.0 X 13.5

**ABBREVIATIONS**

WB = Wheel Base    TYP. = Typical  
C/A = Cab to Axle    C.S. = Customer Supplied  
OAL = Overall Length    N.I.C. = Not In Contract  
OH = Overall Height  
OAW=Overall Width

**CUSTOMER SIGNATURE REQUIRED** CUSTOMER APPROVAL IS REQUIRED PRIOR TO THE START OF PROJECT. BY SIGNING, CUSTOMER IS APPROVING PROJECT TO BE BUILT TO THIS PLAN'S SPECIFICATIONS.

Signature \_\_\_\_\_ Date \_\_\_\_\_

DRAWN BY	LH
DRAWN DATE	08/7/2025
REVISION	0
ORDER NUMBER	32376
SHEET NO.	2

# MODULE DETAIL

## TOP VIEW

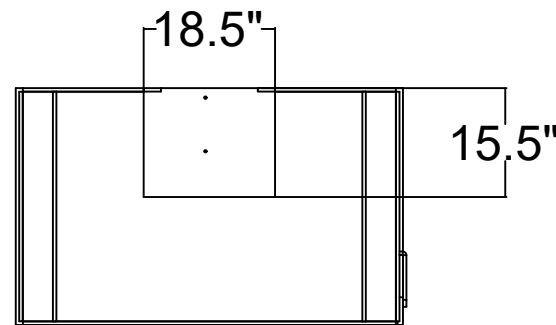
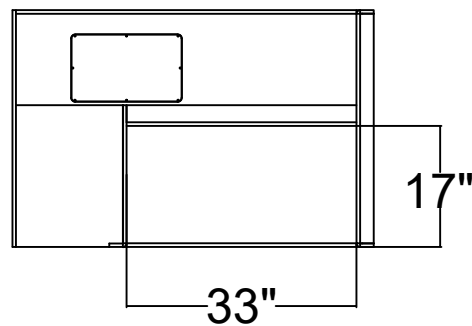
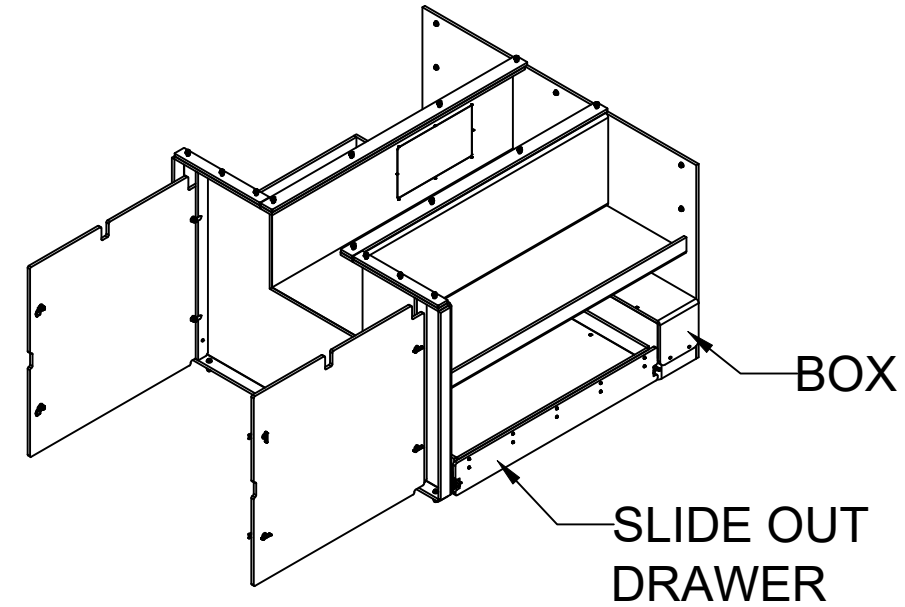
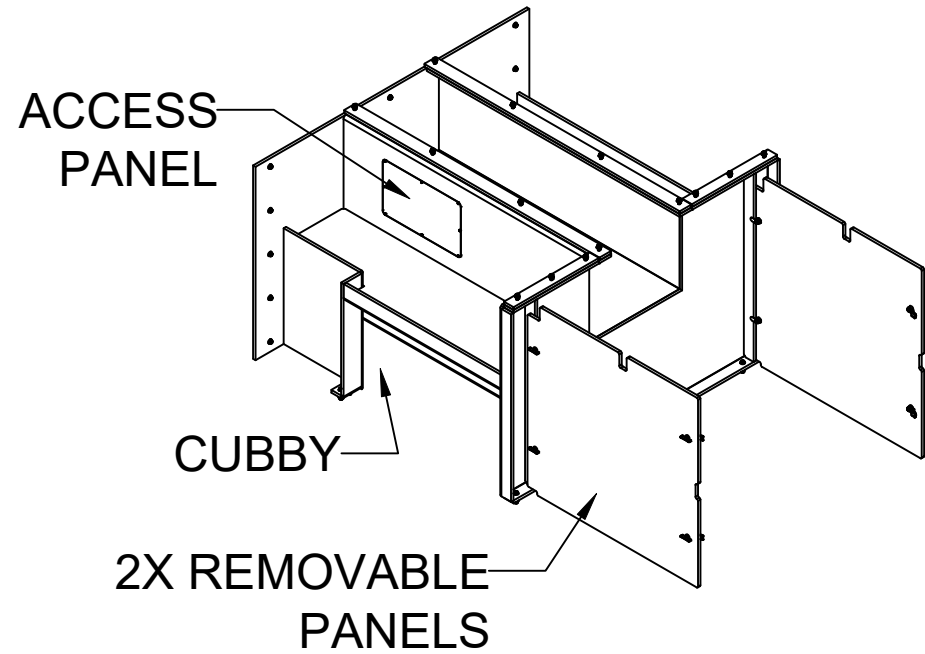
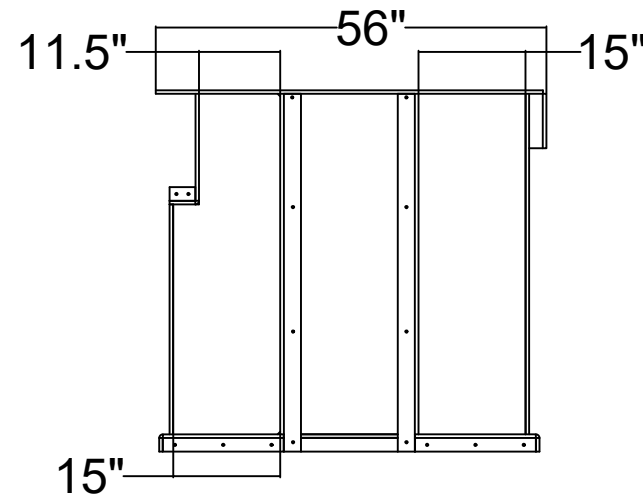

## TGE VIEW

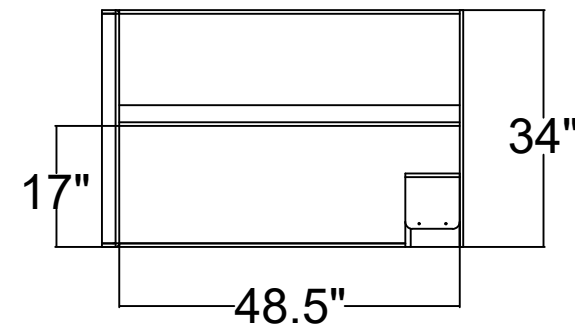

### NOTES

Not all items being specified are shown on this print. Refer to customer specifications for a review of all details.

DO NOT SCALE PRINTS

All dimensions are in decimal inches.

### PROJECT

NEW ENGLAND FIRE:  
COMMAND VEHICLE

### CHASSIS

FORD F350

### COMPARTMENTS

Label	Size	W X H X D	ROUGH OPENING
D1	78.0 X 35.5 X 26.5		78.0 X 35.5
D2	11.0 X 23.5 X 9.0		11.0 X 23.5
R1	43.5 X 35.0 X 33.5		43.5 X 35.0
P1	78.0 X 35.5 X 8.5		78.0 X 35.5
P2	11.0 X 23.5 X 9.0		11.0 X 23.5
P3	11.0 X 13.5 X 9.0		11.0 X 13.5

### ABBREVIATIONS

WB = Wheel Base      TYP. = Typical  
C/A = Cab to Axle      C.S. = Customer Supplied  
OAL = Overall Length      N.I.C. = Not In Contract  
OH = Overall Height  
OAW=Overall Width

**CUSTOMER SIGNATURE REQUIRED** CUSTOMER APPROVAL IS REQUIRED PRIOR TO THE START OF PROJECT. BY SIGNING, CUSTOMER IS APPROVING PROJECT TO BE BUILT TO THIS PLAN'S SPECIFICATIONS.

\_\_\_\_\_  
Signature

\_\_\_\_\_  
Date

DRAWN BY	LH
DRAWN DATE	08/7/2025
REVISION	0
ORDER NUMBER	32376
SHEET NO.	2