

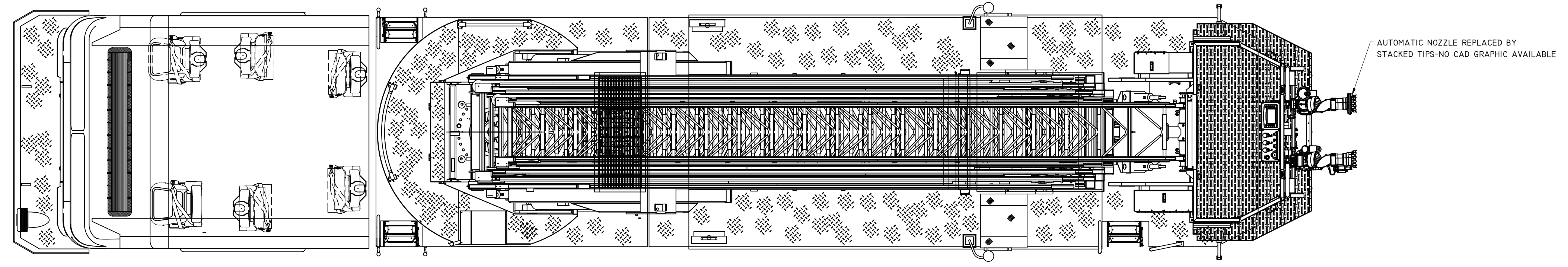

CHASSIS:	SPARTAN GLADIATOR MFD 5"RR
ENGINE:	CUMMINS ISX 565 HP
TRANSMISSION:	ALLISON 4000 EVS W/RETARDER
AXLES:	23,000 LB. FRONT / 58,000 LB. REAR
MODEL:	P45M-93 MID-MOUNT TOWER
WATER/FOAM:	N/A
PUMP:	N/A
FOAM SYSTEM:	N/A
GENERATOR:	HARRISON 10.0 KW

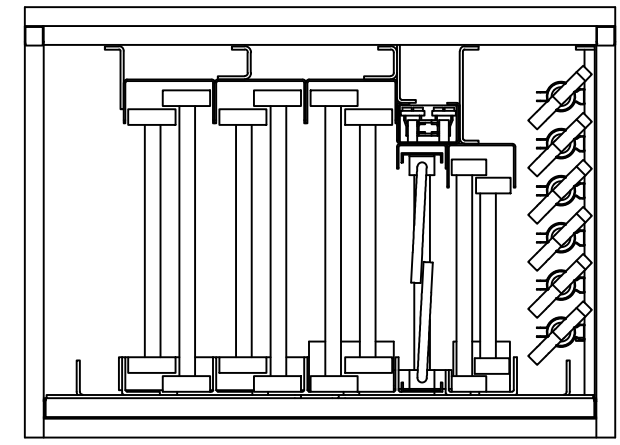

AUTOMATIC NOZZLE REPLACED BY STACKED TIPS-NO CAD GRAPHIC AVAILABLE



LADDER INVENTORY

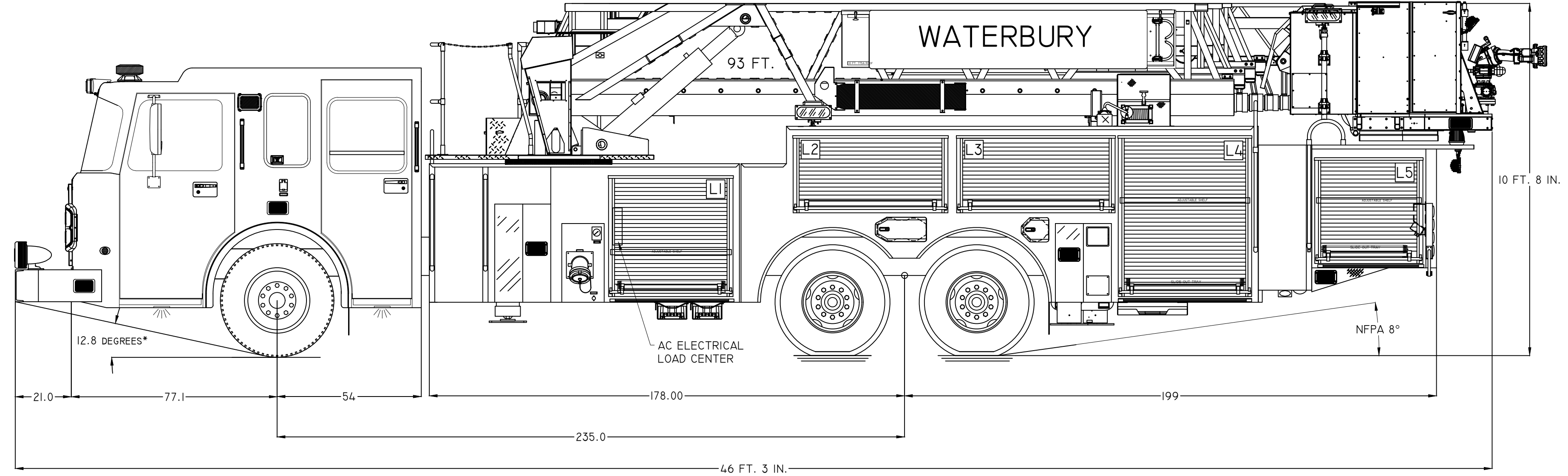
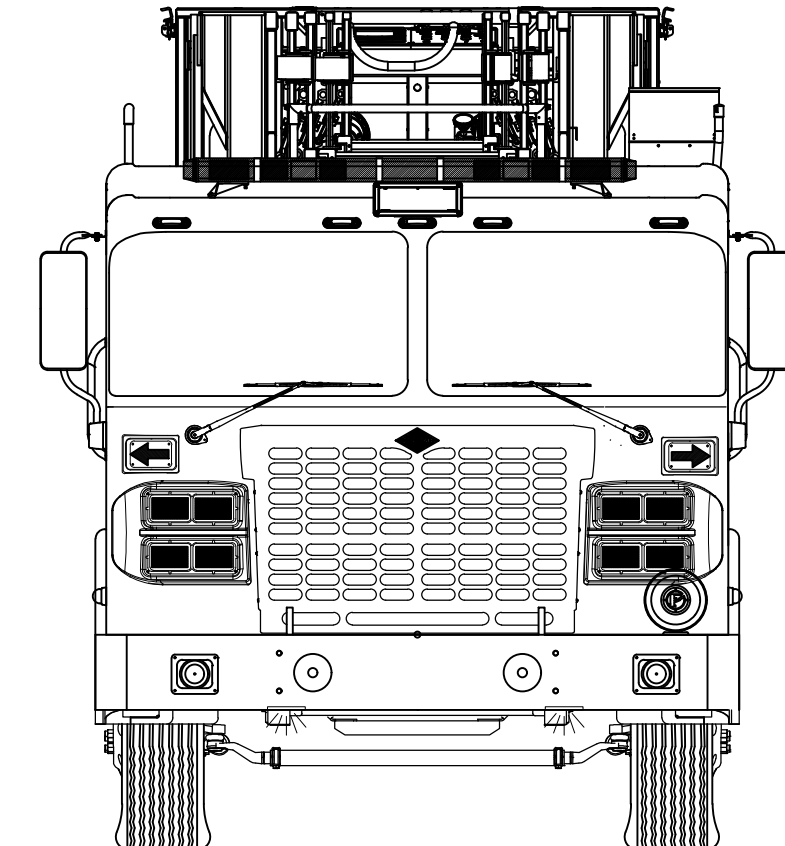

AUTOMATIC NOZZLE REPLACED WITH STACKED TIPS-NO CAD GRAPHIC AVAILABLE

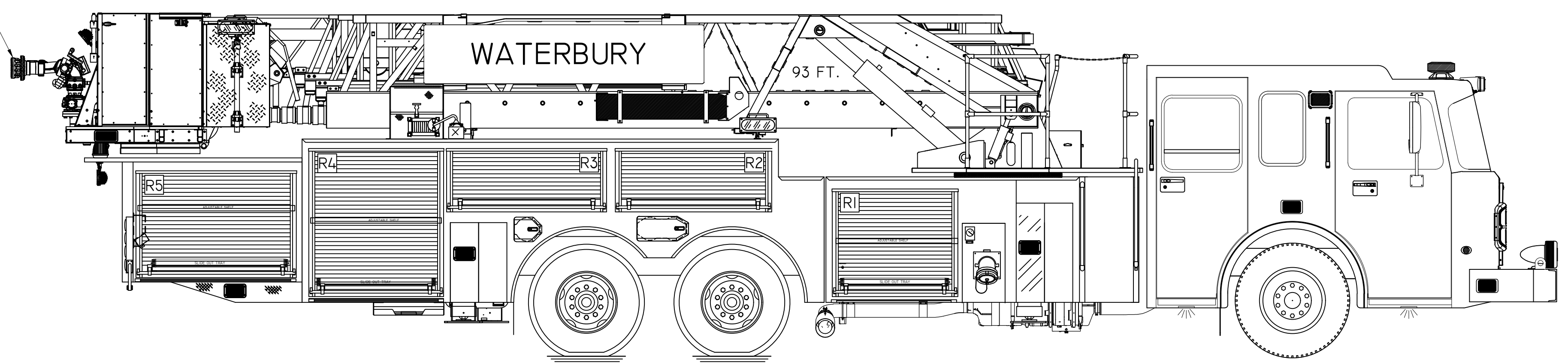
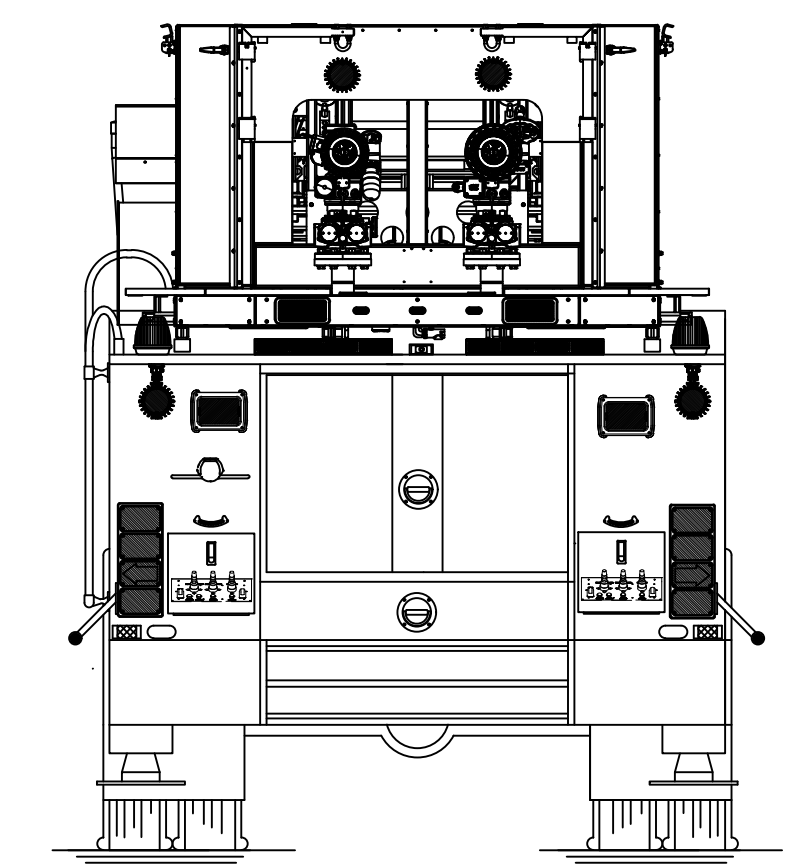

I.D.	FRAME OPENING	INTERIOR DIMENSIONS
L1	46.50 W x 40.87 H	50.25W x 44.25H X 23.38D*
L2	58.00 W x 26.25 H	63.38W x 29.63H X 23.38D
L3	58.00 W x 26.25 H	60.38W x 29.63H X 23.38D
L4	50.00 W x 55.75 H	52.50W x 59.12H X 23.38D
L5	38.75 W x 33.88 H	42.50W x 37.25H X 22.87D
R1	46.50 W x 40.87 H	50.25W x 44.25H X 23.38D*
R2	58.00 W x 26.25 H	63.38W x 29.63H X 23.38D
R3	58.00 W x 26.25 H	60.38W x 29.63H X 23.38D
R4	50.00 W x 55.75 H	52.50W x 59.12H X 23.38D
R5	58.75 W x 33.88 H	62.50W x 37.25H X 22.88D

*COMPARTMENT DIMENSIONS TAKEN FROM MODEL 1008020

- GROUND LADDERS:
- TWO 35 FT. 1200A 2-SECTION
 - ONE 28 FT. 1200A 2-SECTION
 - ONE 14 FT. 1000A 2-SECTION
 - ONE 20 FT. 875DR ROOF
 - ONE 16 FT. 875DR ROOF IN FLY
 - ONE 10 FT. 775DR ROOF ON BASE
 - ONE 10 FT. 585A FOLDING
 - TWO 10 FT. RH-10 CHISEL END HOOKS
 - TWO 8 FT. RH-8 CHISEL END HOOKS
 - TWO 6 FT. RH-6 CHISEL END HOOKS
 - ONE 10 FT. RH-10 GAS VALVE END IN FLY

CUSTOMER

THIS DRAWING IS A CLOSE APPROXIMATION OF YOUR FIRE APPARATUS. IN ALL CASES WHERE THE DRAWING AND THE WRITTEN SPECIFICATION DIFFER, THE SPECIFICATION SHALL PREVAIL. PLEASE WORK WITH YOUR DEALER TO ASSURE THAT THE WRITTEN SPECIFICATION REPRESENTS WHAT YOU WANT IN YOUR FINISHED PRODUCT. SPARTAN EMERGENCY RESPONSE BUILDS TO THE WRITTEN SPECIFICATION, NOT THE DRAWING TO ASSURE THAT YOUR NEEDS ARE MET.

PROPRIETARY AND CONFIDENTIAL
THE INFORMATION CONTAINED IN THIS DRAWING IS THE SOLE PROPERTY OF SPARTAN EMERGENCY RESPONSE. ANY REPRODUCTION IN PART OR AS A WHOLE WITHOUT THE WRITTEN PERMISSION OF SPARTAN EMERGENCY RESPONSE IS PROHIBITED. SPARTAN MOTORS USA, INC. D/B/A SPARTAN EMERGENCY RESPONSE.

REV	DATE	DESCRIPTION	NAME
2	1/18/22	ADDED GROUND LADDERS AS RELEASED	WB
1	10/21/21	UPDATED PER ENG. MARK-UP	WB
0	7/16/19	INITIAL DRAWING	WB

SCALE: NOT TO SCALE

WATERBURY FIRE DEPARTMENT
WATERBURY, CONNECTICUT

TRUCK NUMBER:	DRAWING No.
L220029-01	3-020-0376

*ANGLE OF APPROACH AND ANGLE OF DEPARTURE VERIFIED THROUGH FIELD MEASUREMENTS